**ENUM 2 – Description of Administrative Routines for
ENUM and Prestudy for the Trial**

2002-10-25

Version: C

Table of Contents

1	Scope	3
2	References	3
3	Definitions and abbreviations	4
3.1	Definitions	4
3.2	Abbreviations	5
4	Introduction	6
4.1	About ENUM.....	6
4.2	About the project ENUM 2.....	6
4.3	About this document.....	6
5	Entities and relations	7
5.1	The ENUM Subscriber	9
5.2	Telephone Service Provider (TSP).....	9
5.3	ENUM Registrar	9
5.4	ENUM Tier 2 Name server Provider	10
5.5	Application Service Provider	10
5.6	The ENUM Tier 1 Registry	11
5.7	CRefDB	12
6	Some requirements on a Swedish ENUM.....	13
6.1	Legal requirements	13
6.2	Competition and regularisation	14
6.3	Validation of E.164 Subscribers	14
6.4	Avoid dependences.....	15
7	Swedish ENUM administrative procedures	16
7.1	Management of ENUM Domain Names	16
7.2	Maintenance of NAPTR recourse records.....	18
7.3	Cancellation and Porting of E.164 numbers	19
7.4	Charging	20
7.5	Authorization of ENUM entities	21
7.6	Change of ENUM Registrar.....	21
8	The trial	22
8.1	Instructions for the trial	22
8.2	Participants.....	22
8.3	Identification and validation	23
8.4	Notification of a ending E.164 subscription	23
8.5	Charging	23
8.6	Other administrative functions in the trial	23
9	For further study	24
9.1	Correspondence between ENUM Domains and E.164 Numbers	24
9.2	Automatization.....	24
9.3	Regulation and supervision.....	24
9.4	Charging	25
9.5	PUL.....	25
Appendix A	English–Swedish dictionary	26
Appendix B	Participants in working group ENUM2.....	26
Appendix C	Subjects discussed by ENUM WG2	27
Appendix D	Grouping of entities	28

1 Scope

With ENUM, E.164 numbers can be stored as domain names in DNS (ENUM Domain Names). For each ENUM Domain Name, associated information can be stored in NAPTR resource records. For example associated contact information for; Internet based IP-telephony, e-mail, web, fax number, mobile number etc. This makes it possible to develop a number of new Internet based services.

The Swedish National Post & Telecom Agency, PTS (Post- och telestyrelsen) has launched the preparation phase to perform a national ENUM trial together with interested parties in the telecom and internet industries. To accomplish the task, PTS has organized three working groups having the objectives to outline for a) establishment of a trial ENUM system and b) identification of requirements for future implementation of a commercial ENUM administrative service. The working groups are:

- ENUM 1 – Applications that should be part of the ENUM trial.
- ENUM 2 – Description of Administrative Routines for ENUM and Prestudy for the Trial
- ENUM 4 – DNS Infrastructure for ENUM

This is the report from the working group ENUM 2.

2 References

For the purposes of this document the following references apply:

- [1] IETF RFC 2915, The Naming Authority Pointer (NAPTR) DNS Resource Record
- [2] IETF RFC 2916, E.164 number and DNS
- [3] Draft ETSI TS 102 051 v0.1.6 (2002-04), ENUM Administration in Europe
- [4] Draft ITU-T Supplement, Operational & Administrative Issues Associated with National Implementations of the ENUM Functions”, Draft #11

3 Definitions and abbreviations

3.1 Definitions

For the purposes of this document the following terminology and definitions apply. The definitions collected from ETSI or ITU-T are tagged with the reference [3] for ETSI and [4] ITU-T. There are several other definitions made by ETSI and ITU-T concerning ENUM, but they are not needed in this document.

Application Service Provider: the entity that provides specific application(s), which may be linked to an E.164 number using ENUM e.g. email or voice messaging to the End User. [3]

CRefDB: The Central Reference Database for Number Portability holding reference data for ported directory number from the national numbering plan. (*also ref E.164*)

Note: CrefDB is the term used in ITS standard SS 63 63 91, edition 2

Directory Number: An E.164 number in the National numbering plan assigned to a subscriber for a public telecommunication service.

NOTE: The Directory Number is assigned directly to E.164 subscribers by the Telephone Service Provider from number ranges assigned by PTS.

DNS Service Provider: An entity providing DNS service for subscribers. ENUM Tier 2 Name server Providers are the subset of DNS Service Providers, that provides DNS Service at the ENUM Tier 2 level.

Domain: a set of host names within the DNS consisting of a single domain name and all domain names below it. [3]

E.164: the International Public Telecommunication Numbering Plan [3].

E.164 Subscriber: A person or entity (i.e. a registrant) that is assigned an E.164 number. [4]

ENUM Domain Name: The domain name for an E.164 number, the primary point of reference in ENUM. [4]

ENUM Registrar: the entity that provides direct service to domain name Subscriber by processing name registrations. [3]

ENUM Subscriber: the assignee of an E.164 number who has agreed to insert its E.164 number in the ENUM DNS-based architecture. [3]

ENUM Tier 1 Manager: The entity (ITU Member State(s) or Administration(s)) responsible for the management of the domain for the ENUM CC Level. [4]

ENUM Tier 1 Registry: The entity acting as the registry for the ENUM CC Level. [4]

Registry: The organisation that maintain the registry database, is responsible for master and slave servers, and also creates the zone file for this domain. There is only one registry per DNS zone. [4]

ENUM Tier 2 Name server Provider: The entity responsible for the service within DNS that hold the NAPTR resource record. [3]

Number Portability the ability of an end user to change location within a geographic area, change service provider or change service, without changing their number.

PTS: Post- och telestyrelsen, the Swedish National Regulatory Authority (NRA) for the telecommunications sector. PTS might permanently act as the ENUM Tier 1 Manager for ENUM in Sweden but this is at present under investigation. PTS is the authority that administers the Swedish National Numbering Plan designated by the Country Code 46.

SNPAC: Swedish Number Portability Administrative Center. A company that provides the CRefDB in Sweden.

Telephone Service Provider: The provider of the telephone service associated with an E.164 number in the PSTN, ISDN or PLMN. The service provider often assigns E.164 numbers to subscriber. [4]

Tier 1: level in tiered architecture corresponding to the E.164 Country Code (CC), i.e. <CC>.e164.arpa. Records at this level contain pointers to Tier 2 for an E.164 number. [3]

Tier 2: level in the tiered architecture corresponding to the E.164 number, i.e. <N(S)N>.<CC>.e164.arpa. Records at this level contain NAPTR records for an E.164 number. [3]

3.2 Abbreviations

For the purposes of the present document, the following abbreviations apply:

ASP	Application Service Provider
CRefDB	Centralised Reference Database for Number Portability
DNS	Domain Name system
IETF	Internet Engineering Task Force
ITU-T	International Telecommunication Union - Telecommunication Standardisation Sector
NAPTR	Number Authority Pointer Record
NRA	National Regulatory Authority
RFC	Request For Comment (IETF related standard)
TLD	Top Level Domain
TSP	Telephone Service Provider
URI	Uniform Resource Identifier

4 Introduction

4.1 About ENUM

IETF has defined the ENUM standard (RFC 2916), which describes the method of populating E.164 numbers in the DNS system.

ENUM implies the mapping of E.164 numbers to a NAPTR record for the storage of other URIs, such as, email address. Once the record is created it is then available for any other entity or application that may request the ENUM resolution of an E.164 identity.

In its simplest form, a human at a computer who wishes to discover the availability of other contact information associated with an E.164 number, may use the ENUM resolution to obtain a NAPTR record. Alternatively, the NAPTR record may be requested by client software resident in an end user's PC, in a network or elsewhere.

4.2 About the project ENUM 2

The ENUM 2 group has had six meetings during April to June 2002, with the objective of clarifying the administrative routines of ENUM Domain Names service, including:

- the registration and customer process regarding ENUM Subscribers,
- principles for payment between the actors,
- to evaluate who can act as ENUM Registrar, Names server providers, etc.

As work started, the group made some priorities and major conclusions

- The scope for the group could be summarized as "How to implement the administrative service necessary for providing ENUM in Sweden", i.e. the administration routines have to be analysed from a commercial view rather than a trial system only.
- Define the entities involved in ENUM
- Propose an organisational structure that will work in the long-range perspective before specifying the organisation and administration for the national trial.
- Specify the requirements for an efficient and open ENUM-administration process, serving the whole industry based on fair competition for all.

4.3 About this document

This report is focusing on procedures and roles for a long-term commercial (i.e. permanent) solution covering the administration of ENUM in Sweden. Only the succeeding "trial" chapter is focusing on the short-term solutions.

4.3.1.1 Topics covered in this report

This report is not a complete specification. It is rather a baseline, which can be used as input for further work to accomplish full commercial administrative support for ENUM.

In chapter 5 the entities involved in ENUM administration and their relations are described. In chapter 6 some overall requirement for the administration of Swedish ENUM is stated.

In chapter 7 an overview of the administrative procedures for ENUM is given.
In chapter 8 things to address in the ENUM trial is mentioned.
In chapter 9 a list of questions for further study is specified.

4.3.1.2 Topics not covered in this report

The method of interconnecting private ENUM like implementation to public ENUM is outside the scope of this document. Private ENUM like implementation refers to someone that uses the ENUM principle and the DNS technology to create an internal operated ENUM type of service, e.g. for the mapping of own private numbering plan identities to other Internet identities).

Furthermore, the possibility to use ENUM for storage of operator's identity serving a specific E.164 Number is also outside the scope of this document.

5 Entities and relations

The following entities has been identified as relevant for the support of ENUM administration:

- Application Service Provider
- ENUM Tier 2 Name server Provider
- ENUM Subscriber
- ENUM Registrar
- ENUM Tier 1 Registry
- Telephone Service Provider
- CRefDB

All of them have also been defined by ETSI and/or ITU-T (see chapter 3).

The intention of defining these entities is to prevail full flexibility and competition among the providers of services necessary for ENUM in Sweden. For instance, the ENUM Registrar could be provided within a Telephone Service Provider, one of .SE's (the swedish TLD) ordinary Registrars, an Application Service Provider, or a totally new player.

E.g. it is very likely that a TSP would like to offer their customers all the services needed for registration and running applications based on ENUM (one stop shopping). In that case the TSP will also have to implement the Functions of; ENUM Registrar, ENUM Tier 2 Name server Provider and Application Service Provider. More discussions on how the different entities could be grouped are given in appendix D.

Some of the "Entities" are bound by legal acts more than others. For the purpose of removing any ambiguity when exploring the relation between ENUM related entities, the following principles applies:

- The ENUM Subscriber is a physical or juridical person.
- A Telephony Service Provider illustrate an operating entity that comply to the requirements as regulated by Swedish Telecommunication Act (Telelagen).
- The current assumption is that the CRefDB and of ENUM Tier1 Registry is going to be handled by separate legal entities appointed by and supervised by the ENUM Tier 1 Manager.

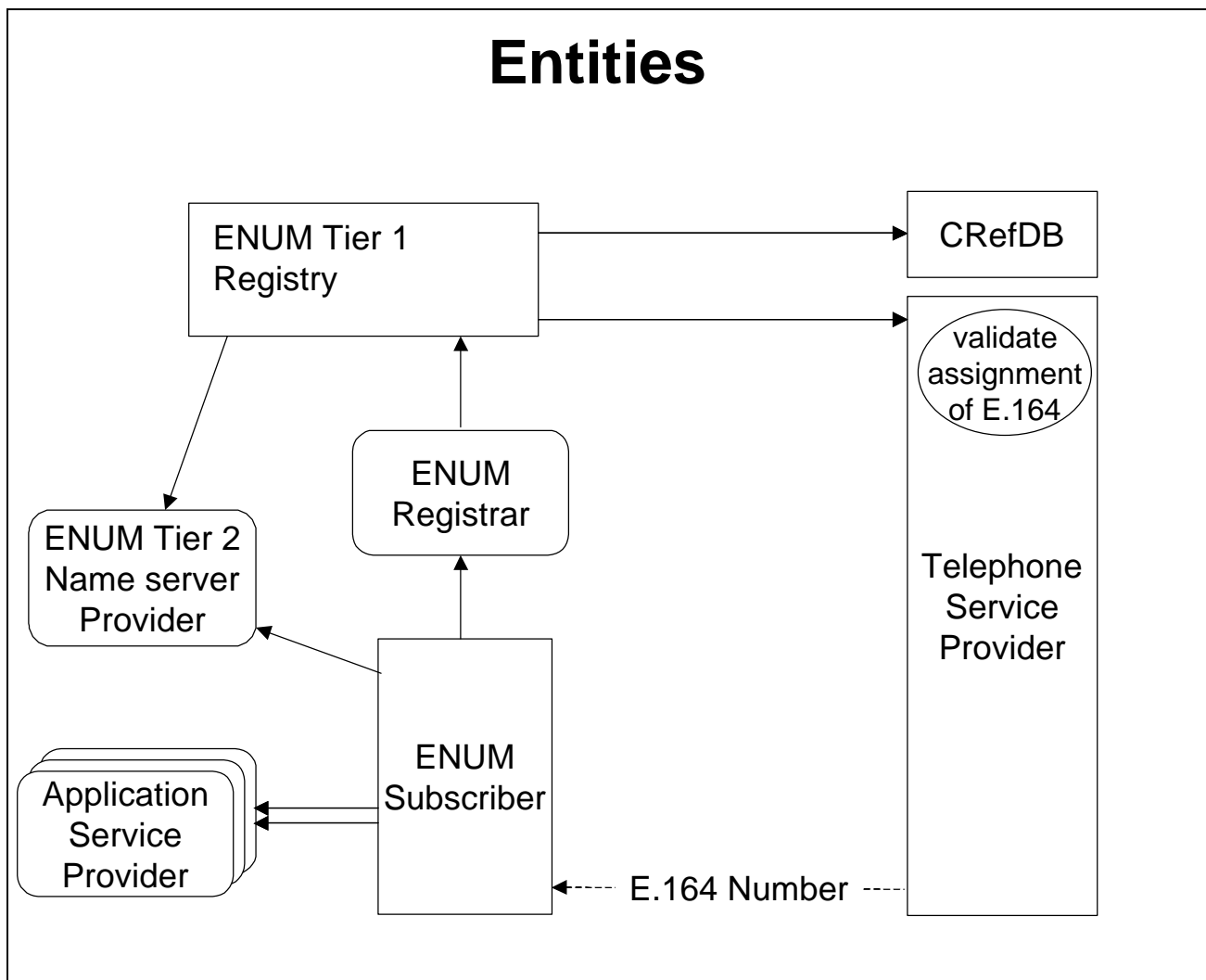

Figure 1 – Entities needed for the administration of ENUM.

The relations between the entities are discussed further in the coming chapters. Below are some important remarks for the different entities.

5.1 The ENUM Subscriber

- The ENUM Subscriber must be the E.164 Subscriber.
- When the subscription of the E.164 number ends all information concerning the ENUM Subscriber shall be removed from the ENUM Domain Name.
- It is the responsibility of the ENUM Subscriber to choose one ENUM registrar, for processing the registration of the ENUM Domain Name.
- The ENUM Subscriber should be able to assure that the information stored in NAPTR resource records is correct.
- It is the right of the ENUM Subscriber to choose any ASP(s).

5.2 Telephone Service Provider (TSP)

- Only TSPs can assign E.164 Numbers to subscribers in Sweden (+46).
- To assure that an E.164 subscriber and an ENUM subscriber are identical for a specific E.164 number the TSP must assist with:
 1. **ENUM validation;** Confirming to ENUM Tier 1 Registry, that a person actually is assigned an E.164 number.
 2. **ENUM cancellation;** The TSP must report to ENUM Tier 1 Registry when a ENUM Subscriber is no longer assigned the E.164 number (E.164 subscription cancelled or number exported). The Tier 1 delegation shall be removed so that all DNS ENUM data associated with that E.164 number disappears. This is unless the number is ported to another TSP that confirms the ENUM subscription.
 3. **ENUM update;** The importing TSP must confirm to ENUM Tier 1 Registry when an E.164 number is imported.

A TSP that assists the ENUM administration procedures is referred as “ENUM enabler TSP”.

Note 1: How the ENUM administrative relation should be handled to TSP that will not be classified as “ENUM enabler TSP” is for further study. One possibility is that the E.164 numbers belonging to such a TSP could not be used as ENUM Domain Name. The E.164 Subscriber has always the possibility to port the number to a TSP that is ENUM enabled.

Note 2: ENUM Update can be solved in the following way. The TSP must report to CRefDB when an E.164 number is ported. This information is subsequently distributed by the CRefDB to the ENUM Tier 1 Registry.

5.3 ENUM Registrar

The ENUM Registrar represents the ENUM Subscriber towards ENUM Tier 1 Registry, concerning the registration process for an ENUM Domain Name. The ENUM Registrar:

- is authorized by the ENUM Tier 1 Registry and should be registered before it gets operational.
- is responsible for identifying the applicant to become an ENUM Subscriber, to avoid unauthorized registrations.
- is responsible for sending in a complete application to the ENUM Tier-1 Registry concerning the ENUM Subscribers registration.
- shall handle the invoicing of the domain name registration and management and Tier 1 service offered to an ENUM Subscriber.

Competition, concerning price, service, presence etc, shall prevail between ENUM registrars. The ENUM Subscriber shall be free to choose and change ENUM Registrar.

5.4 ENUM Tier 2 Name server Provider

A DNS Service Provider is a generic term for somebody running a DNS Server and maintaining any kind of DNS-data for subscribers. The role of DNS service provider is a well established in the Internet. There is a long experience in the management of Domain Name for subscribers, i.e. managing e-mail, web and resource records for other services. An ENUM Tier 2 Name server Provider is a DNS Service Provider that holds the NAPTR resource at ENUM Tier 2 level. In a technical sense there is no obvious difference between a traditional DNS Service Provider and an ENUM Tier 2 Name server Provider. There is also a wish from the ENUM2 group that the existing great flexibility for DNS services should be pertain when handling NAPTR resource records. However it can not be excluded that there will be a need to have specific handling or requirements for those DNS Service Providers that are ENUM Tier 2 Name server Providers.

The ENUM Tier 2 Name server Provider can be implemented within the ENUM Subscribers own organisation, an Internet Service Provider, a TSP, an ASP, a web hotels, a private person, etc. Today, DNS Service Providers are has been self regulated by the market, without any legal regulations, which has proven to be a successful concept
It is the rights of subscriber to choose a DNS Service Provider that provides the right price/performance.

Therefore, it should also be the ENUM Subscriber's right to choose the ENUM Tier 2 Name server Provider that should handle its ENUM Domain Name.

- Competition, concerning price, service, presence etc, shall prevail between ENUM Tier 2 Name server Providers.
- A ENUM Subscriber shall be free to choose and change ENUM Tier 2 Name server Provider (and could be its own ENUM Tier 2 Name server Provider).

The ENUM2 group has discussed, if quality requirements and some sort of regulation is needed or if self regulation shall be preferred for ENUM Tier 2 Name server Provider. There have been different opinions on this and the question has to be further discussed.

How the NAPTR resource records are updated and managed is a local matter authorized by the ENUM Subscriber. How the ENUM Subscriber, the ENUM Tier 2 Name server Provider and the Application Service Providers communicate in the process to update the ENUM NAPTR resource records are outside the scope of this document.

5.5 Application Service Provider

On the Internet the DNS-service and Applications are clearly separated. DNS only provides a lookup service for the application, without knowing any details about the application. From a DNS point of view, there should be no difference between ENUM based Applications and traditional Internet Applications as; e-mail and web.

Application Service Provider, that provides specific ENUM based applications, should be handled as "ordinary" Application Service Providers on Internet (e.g. web or mail service providers), therefore:

To facilitate the ability for supporting as many new ENUM-based applications as possible, the ENUM-service shall impose minimal restrictions for ENUM based Application.

It is the responsibility of the ENUM Subscriber to choose among Application Service Providers. The DNS system should not impose any restrictions on the number of Application Service Providers a ENUM Subscriber can have at the same time

The ENUM Subscriber has the ultimate responsibility for the content of the NAPTR records, corresponding to the ENUM based application. How they are updated and managed is a local matter concerning the ENUM Subscriber, the ENUM Tier 2 Name server Provider and the Application Service Provider, and outside the scope of this document.

5.6 The ENUM Tier 1 Registry

The design of ENUM in Sweden should avoid having the Subscribers being “locked in” by the players in ENUM. When an ENUM E.164 Subscriber changes his TSP, Application Service Provider, ENUM Tier 2 Name server Provider or ENUM Registrar, no functional dependence should remain to the old provider. This could be achieved by having one single ENUM Tier-1 Registry for Sweden.

It is assumed that ENUM Tier 1 Registry will operate under strict supervision by a neutral part for guaranteeing the neutrality and open competition towards the whole industry.

5.6.1 Functions provided by ENUM Tier 1 Registry

The functionality of the ENUM Tier 1 Registry is to:

- Provide a DNS service for .64.e164.arpa and delegation to other ENUM Tier 2 Name server Providers for ENUM Domains.
- Managing registrations of ENUM Tier 2 Name server Provider (Delegation, Re-delegation and Removal) for ENUM Domain Names.
- Validate that the applicant is the actual E.164 Subscriber (The implementation is for further study)
- Remove delegations of ENUM Domains when the subscription of an E.164 number ends.
- Managing the ENUM Registrars

5.6.2 Responsibility and authority

The administration of Swedish E.164 national numbering plan is under the authority of PTS through legal mandate from the Swedish Government. PTS doesn't today manage assignment E.164 numbers to subscribers and has no intention to manage registration of ENUM Domain Names to ENUM Subscribers. The role of the NRA in a future permanent ENUM environment is at present under investigation by PTS on the request by the Government. However PTS is expected to be the ENUM Tier 1 Manager for Sweden for the trial period.

The functions within ENUM Tier 1 Registry should be implemented within a single organisation serving all the Swedish E.164 numbers. The reasons are:

- All parties involved in ENUM in Sweden are dependent on the quality of this service. Therefore a single ENUM Tier 1 Registry under the efficient supervision of ENUM Tier 1

Manager is very important. It is also easier for the Tier 1 Manager to supervise a single organisation than several.

- Because of hierarchical structure of DNS, there is no known distributed technical solution avoiding the need for a central administration at the Tier 1 level.

As a consequence of having ENUM Tier 1 Registry operating alone, special requirements have to be met by an authorised ENUM Tier 1 Registry, e.g.:

- ENUM Tier 1 Registry shall be kept as small as possible. Functions that don't have to be performed by the ENUM Tier 1 Registry should not be included.
- Insuring the requirements on availability of the technical DNS service and the administrative functions provided by ENUM Tier 1 Registry.
- Insuring the requirement on capacity, response time, automation, ...
- Insuring the requirements on authenticity of the stored information
- Insuring the requirement on cost effectiveness

The Tier 1 Manager must supervise the administration and operation of the Tier 1 Registry so that:

- The terms and conditions (and pricing) and operational requirements is acceptable
- It is guaranteed that ONLY the holder of an E.164 number can authorize introduction of an item for the associated E.164 domain-name.

5.7 CRefDB

The administrative role and use of the CRefDB is to be defined.

Some experience can be made from SNPAC that has already implemented some of the CRefDB functions needed for the administration of ENUM.

In accordance with the proposed ENUM administrative procedures, described in section 6.3, a check has to be made to find out which TSP that is responsible for a certain E.164 Number for the purpose of pertaining the correlation between ENUM and E.164 national numbering plan. SNPAC, within its role of providing reference data for ported numbers in Sweden, has the relation between ported E.164 numbers and TSP. A number not ported is under the responsibility of the TSP that PTS assigned the number block.

The validation of subscribers assigned to a Directory Number could possibly also be managed through the CrefDB structure.

6 Some requirements on a Swedish ENUM

6.1 Legal requirements

As the DNS system is an open system, all information registered in a NAPTR resource record can be considered to be publicly available. Therefore special attention has to be given to handling of unlisted (ex-directory) numbers, of “opt-in” rules, and of PUL, Personuppgiftslagen

6.1.1 Legal rules associated with unlisted (ex-directory) numbers

The 24-28 §§ in the Swedish Telecommunication ordinance implies that Swedish citizens have their rights for protecting their integrity. In the Telecommunication systems (PSTN, ISDN, GSM, NMT 450), the Telecommunications Ordinance has been realised by specific services referred as “calling/connected/forwarding/... line presentation restriction”, which prevents the presentation of a user E.164 number to the remote party. All numbers that have been assigned any of the restriction services are referred as unlisted (ex-directory) numbers or restricted numbers on the request by the subscriber/user via supplementary service CLIR.

It is also the responsibility of any entity or system receiving a presentation restriction signal from a Telecommunication system to maintain this information and restriction in the further handling of a call.

Thus, unlisted (ex-directory) number implies that user ID cannot be revealed to remote users and not inserted in white/yellow pages. This “secret” handling of subscription information helps in achieving the integrity of a user in Telecommunication system.

From a DNS perspective, “secret” E.164 numbers have to be handled with precaution not to reveal any user specific information in an ENUM NAPTR resource record. Consequently, an ENUM NAPTR record associated with a unlisted (ex-directory) number may contain Tel-url (a copy of E.164 ID) and other related NAPTR resource records which in combination can reveal a user ID. Furthermore, WHOIS service shall be restricted for “secret” Directory Number.

6.1.2 Legal rules associated with “Opt-In rules

The coming communications data protection directive, as specified by the European Commission, implies that all user data in the electronic communication systems has to be handled on the basis of “Opt-in” rules.

Thus, Opt-in rules for ENUM would imply that, it is prohibited to insert data in the DNS NAPTR resource records without the consent of the subscriber!

This result in a restrictive handling of DNS NAPTR resource records; i.e. any DNS ENUM lookup query of an E.164 number which is not an ENUM Subscriber (i.e. who has not agreed to insert its E.164 number in the ENUM DNS-based architecture) may only be treated with a default mapping of the received DN into a tel-url..

6.1.3 PUL, Personuppgiftslagen

Other PUL-topics then those mentioned in chapter 6.1.1 are outside the scope of ENUM 2.

6.1.4 Swedish Telecommunication Act

Swedish Telecommunication Act applies regulations on TSP:s in order to maintain a stable and efficient telecommunications network in Sweden. Examples are requirements on number portability, quality of service, reports to the PTS, supervision from the PTS, dispute handling and regulations on interconnect pricing.

When introducing ENUM with this concept ASPs and ENUM Tier 2 Name server Providers could also be subject for this types of regulations in order to secure the overall purpose of the Law. The effects of regulation on ASP's and ENUM Tier 2 Name server Providers may severely affect the willingness to act in those roles and thus affect the success of the concept. Thus it ought to be part of the national ENUM trial. IP-telephony and ENUM also opens up for new kind of TSP's (offering only IP-telephony maybe with restricted sets of services with respect to what numbers that can be called).

6.2 Competition and regularisation

Self regulation shall be preferred as far as possible concerning the following entities:

- Application Service Provider
- ENUM Tier 2 Name server Provider
- ENUM Subscriber
- ENUM Registrar

Instead competition shall prevail. Price, service, availability, integrity and other quality parameters shall be left to competition and consumer representatives (e.g. konsumentombudsmannen). However this is a great responsibility, because a badly maintained ENUM-service can lead to unavailability and even frauds with the A-subscriber identities etc. How this market should be supervised is for further study.

The ENUM market shall also be open for new participant and business models as well as to traditional TSPs.

The requirement for how the ENUM Subscriber is allowed to update its own NAPTR resource records, shall be compared to the requirement on “*XX#”-supplementary services. That is, no actions will be taken in case the ENUM Subscriber mess up its own data.

Instead of competition, the ENUM Tier 1 Registry shall be put under regulation.

6.3 Validation of E.164 Subscribers

6.3.1 Requirements and assumption

- To get an ENUM Domain Name, the applicant must be the subscriber of the corresponding E.164 Number.

When an E.164 Subscription ends, any ENUM NAPTR record associated with that E.164 number must be disabled. It is under current assumption that in such a case the responsibility relies on

ENUM Tier 1 Registry to remove the delegation of the corresponding ENUM Domain.

- As the TSPs has the original information about the identity of an E.164 Subscriber, it is essential to insure the involvement of the TSPs in the validation process.

6.3.2 The validation process

The validation process could be performed in the following three steps:

1. The ENUM Registrar identifies the applicant that wishes to become an ENUM Subscriber
2. At the Tier-1 level a check is made to find out the TSP responsible for the E.164 Number in question.
3. At the Tier-1 level a check is made that the applicant actually is assigned the corresponding E.164 Number. This check is made against the identified TSP (see item 2 above) that is responsible for the E.164 Number in question

6.3.3 Notification of an ending E.164 subscription

Today, there exists no defined routine that could notify the ENUM Tier 1 Registry when a E.164 Subscription ends in order to remove the delegation of the corresponding ENUM Domain.

Note: For having a proper solution it is foreseen that the TSP will have to assist ENUM with proper routines!

6.3.4 Implementation of validation and “end of E.164 subscription” notification

How the validation function at the Tier 1 level should be implemented is for further study.

- It is under the assumption of ENUM 2 working group that Tier 1 registry uses information from the Swedish Number plan, the CRefDB and TSP's providing the following three functions: Validate the TSP responsible for a specific E.164 Number.
- Validate that the applicant is assigned an E.164 Number.
- Announce when a E.164 Subscription ends

One solutions that has been discussed is to use the structures for information exchange with TSP:s currently implemented through the CRefDB. However, to determine the feasibility of this and other approaches requires further analysis and investigations with the parties involved.

6.4 Avoid dependences

Dependences between competing entities; i.e. Application Service Provider, ENUM Tier 2 Name server Provider, ENUM Subscriber ENUM Registrar and TSP in terms of operational structures and routines, shall be avoided as far as possible.

7 Swedish ENUM administrative procedures

This chapter outlines the administrative procedures necessary for providing ENUM in Sweden. The following processes are identified:

- Management of ENUM Domain Names
- Maintenance of NAPTR recourse records
- Cancellation or Porting of E.164 Numbers
- Charging
- Authorization of ENUM entities
- Change of ENUM Registrar

7.1 Management of ENUM Domain Names

Three different tasks are identified, for managing the ENUM Domain Names, they are:

- **Delegation.** To register a delegation to a ENUM Tier 2 Name server Provider of a previous unassigned ENUM Domain Name.
- **Re-delegation.** A re-delegation of an ENUM Domain Name to a new ENUM Tier 2 Name server Provider.
- **Removal.** A removal of an ENUM Domain Name.

7.1.1 ENUM Subscriber invoked operation

For all of the tasks (Delegation, Re-delegation or Removal), the following flow is defined:

1. A request is made from the applicant (the ENUM Subscriber or the applicant that wishes to become an ENUM Subscriber)
2. Identification. The ENUM Registrar identifies the applicant.
3. The ENUM Registrar sends a complete application (Delegation, Re-delegation or Removal) to the ENUM Tier-1 Registry as a proxy for the applicant.
4. The Tier 1 Registry initiates a validation process by sending a query towards the CRefDB to find out which TSP that has the responsibility for the E.164 Number.
5. The Tier 1 registry sends a query to the identified TSP for validating that the applicant is actually assigned the E.164 Number.
6. The ENUM Tier 1 Registry updates the information about the ENUM Tier 2 Name server Providers for the corresponding ENUM Domain Name.

Managing of ENUM Domain Names

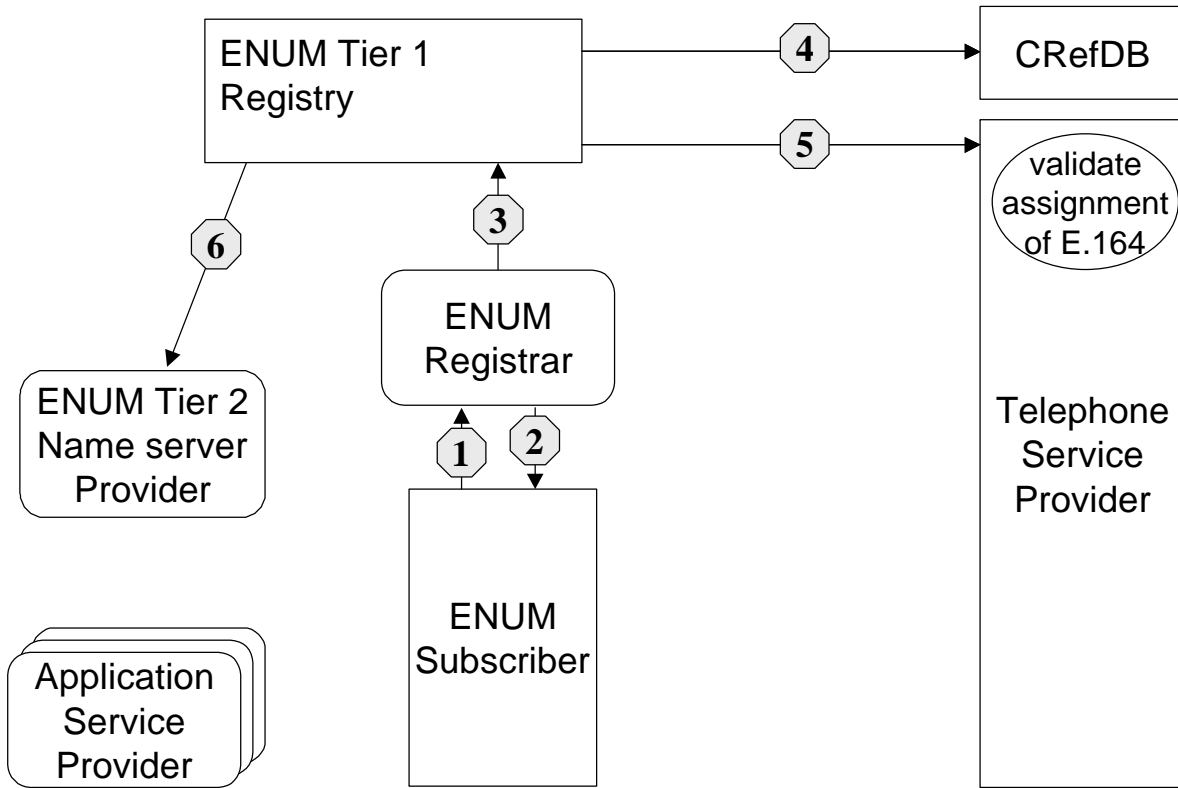

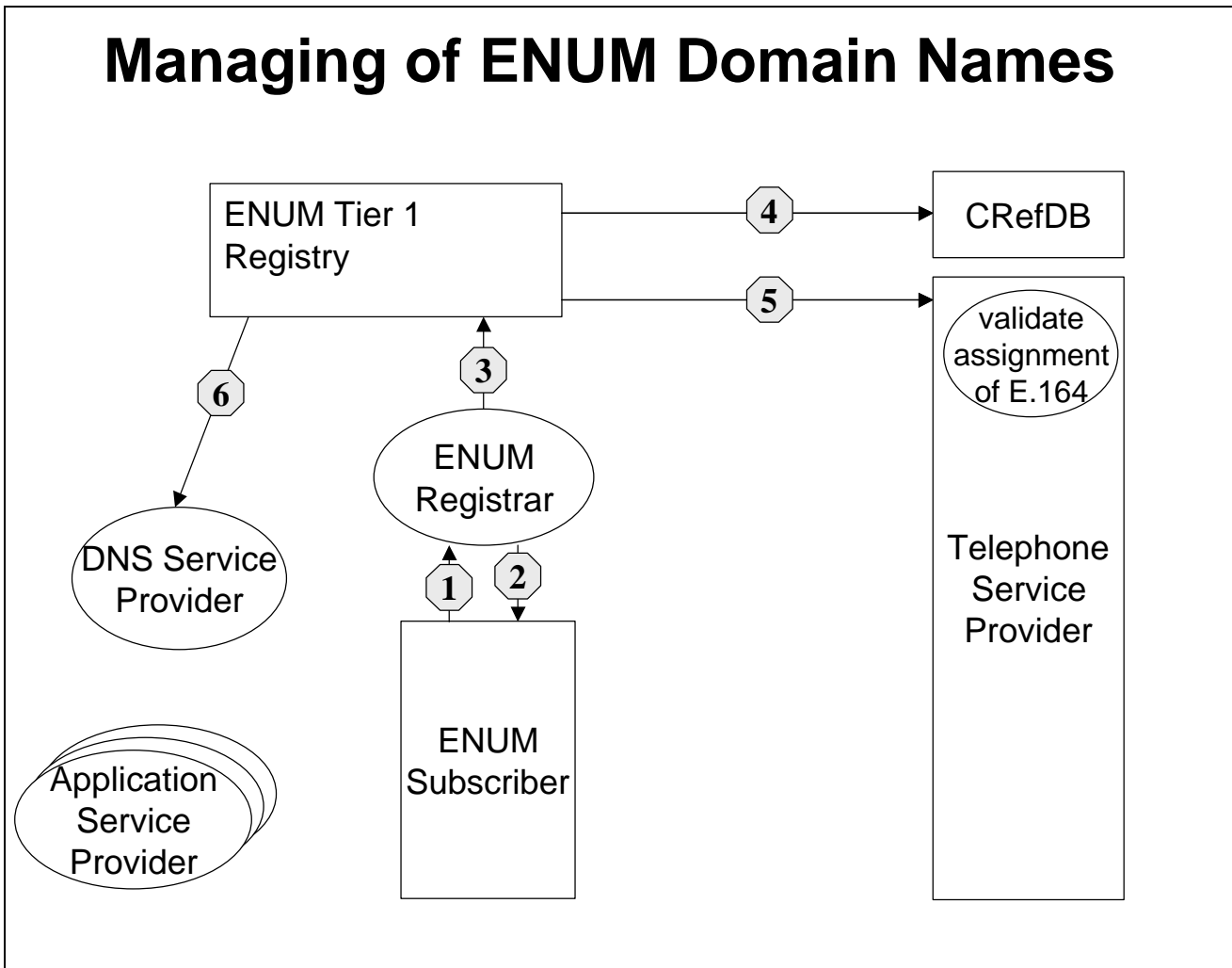

Figure 2 - Management of ENUM Domain Names

The following flows must also be defined:

- ENUM Registrar invoked operation
- ENUM Tier 1 Registry invoked operation
- TSP invoked operation

7.2 Maintenance of NAPTR recourse records

How the NAPTR resource records are updated and managed is a local matter only concerning the ENUM Subscriber, the ENUM Tier 2 Name server Provider and Application Service Providers. However two examples are given below.

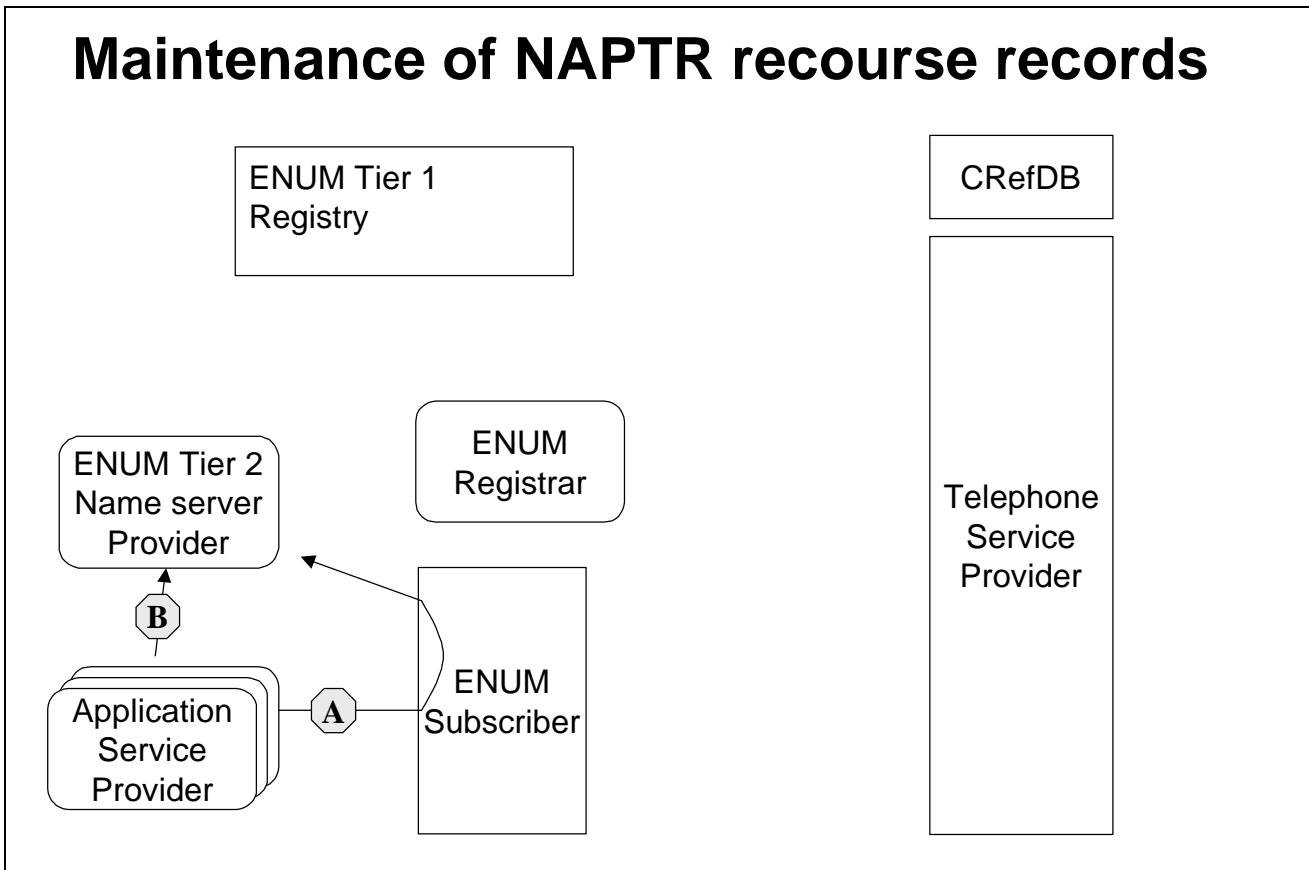

Figure 3 – Example of Maintenance of NAPTR recourse records

It is the responsibility of the ENUM Subscribers to update the NAPTR data. This could be done by the ENUM Subscriber himself (A) or by the ASP (B) if a consent from ENUM Subscriber is obtained.

7.3 Cancellation and Porting of E.164 numbers

7.3.1 Cancellation

The TSP must in some way report to the ENUM Tier 1 Registry when an ENUM Subscriber is no longer assigned the E.164 Number (e.g. because of cancellation of the subscription), So that the delegation of the corresponding ENUM Domain can be removed. This routine is for further study.

7.3.2 Number Portability

When a portability process has been accomplished for a specific E.164 number, the original TSP must notify ENUM Tier 1 Registry of the cancellation of subscription due to ported E.164 Number. This is to assure that ENUM Tier 1 Registry knows that the TSP that hands over the E.164 Number no longer has the responsibility for consistency between the E.164 Number and ENUM Domains. This is for further study.

The Number Portability operation mustn't result in a temporary interrupt of the service from the ENUM Tier 2 Name server Provider.

ENUM Tier 1 registry must validate the portability of E.164 by sending a query towards the CRefDB to find out which TSP that has the responsibility for that ported E.164 Number. In case the new TSP, as result of a portability process, has not been identified as a "ENUM enabler TSP" then a cancellation of ENUM domain associated with the ported number must be performed.

Note 1: The Number Portability operation doesn't necessarily have to result in a change of the ENUM Tier 2 Name server Provider.

Note 2: The information and notification of ported E.164 number can be obtained through the existing services provided by SNPAC (i.e. a standard SNPAC subscription)

7.4 Charging

Charging will take place between several of the entities within ENUM. Some of the charges have to be public regulated while others are up to the market to decide. In the figure below, the expected flow of charges are identified.

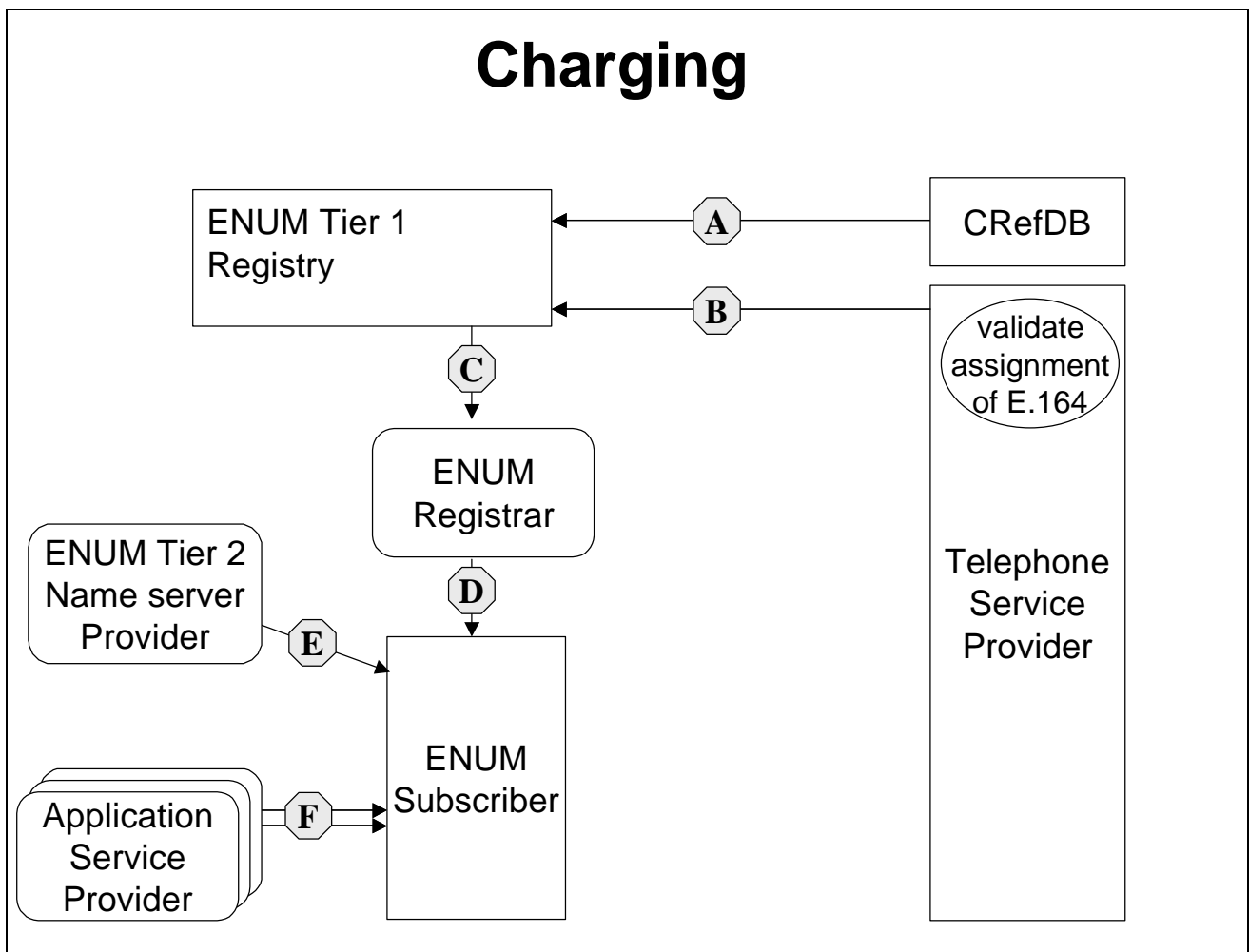

Figure 5 – Charging

- A) The CRefDB is charging the ENUM Tier 1 Registry for the service of telling which TSP a specific E.164 Number is assigned to.
 - B) Whether the TSP should charge the ENUM Tier 1 Registry for the service of validating that the applicant is assigned an E.164 number, or not, is for further study.
 - C) The ENUM Tier 1 Registry is regularly charging the ENUM Registrars, for the service ENUM Tier 1 Registry provides to the ENUM Subscribers who belongs to the ENUM Registrar.
 - D) The ENUM Registrar charge the ENUM Subscriber for the service it provides and for the service provided by the ENUM Tier 1 Registry.
 - E) How the ENUM Tier 2 Name server Provider charge the ENUM Subscriber is subject to the commercial agreement between the ENUM Subscriber and the ENUM Tier 2 Name server Provider.
 - F) How the Application Service Provider charge the ENUM Subscriber is subject to the commercial agreement between the ENUM Subscriber and the Application Service Provider.
- A pricing structure based on fixed as well as recurring charges from the Tier-1 Registry has been identified as a possible method for financing of the Tier-1 operations. The detailed implementation should however be subject to further analysis and study.

The pricing structure used between all other parties should however be subject to individual commercial agreements and competition with no or minimum regulations.

7.5 Authorization of ENUM entities

Any ENUM Registrar or TSP wishing to be part of the administration of ENUM in Sweden, needs to be approved and registered by the Tier 1 registry. At any time information related to a specific entity participating in the administration of ENUM should be updated and published by the ENUM Tier-1 Registry. The ENUM Tier-1 Registry is also responsible to assign unique identities to the entities.

Any entity wishing to erase its participation in the administration of ENUM in Sweden needs to de-register.

If the ENUM Tier 2 Name server Provider also has to be part of the registration procedures is for further study.

7.6 Change of ENUM Registrar

The ENUM Subscriber shall be able to change ENUM registrar. Procedures for such change should be subject to further study!

8 The trial

There are several important issues that the ENUM2 working group would like the Swedish ENUM trial to address. It is important that the organization for the administration of the trial as far as possible is in compliance with the organization suggested in chapter 5-7. This is because a good organization and administration of ENUM in Sweden is a key factor for success and the trial is an excellent opportunity to test the organizational theories.

8.1 Instructions for the trial

It is essential that some aspects of the trial is established before the test is started:

- What is the purpose of the trial, i.e. which are the questions that the trial will answer
- End time for test. The trial can't be the starting point for "real life production"
- What experiments are needed in order to get these answers?
- What are the "rules" for participating in the trials
 - Are there any "over-head costs"
 - How can it be assured that the results of the experiments will be public
 - Other "rules", who can participate, restriction on service etc.

8.2 Participants

There should be some representatives for all type of entities in the ENUM trial and they should take an active part.

8.2.1 ENUM Subscribers

No one is committed yet!

8.2.2 ENUM Registrars

No one is committed yet!

8.2.3 ENUM Tier 2 Name server Provider

No one is committed yet!

8.2.4 TSP

The TSP's that have got E.164 Subscribers participating in the trial should be encouraged to participate.

8.2.5 The ENUM Tier 1 Registry

The tasks of the Tier 1 Registry can possibly be divided into different organizations, e.g.;

- Provide the DNS service
- Managing the registrations
- Validate the applicant
- Managing the ENUM Registrars

No one is committed yet!

8.2.6 CrefDB

No one is committed yet!

8.3 Identification and validation

Some identification and validation of the ENUM Subscribers shall be made during the trial. It should be a mission for the trial to try and find good solutions of this problem.

8.4 Notification of a ending E.164 subscription

The trial shall try to find good solutions on how ENUM Tier 1 Registry shall be notified when an E.164 Subscription ends, so that the delegation of the corresponding ENUM Domain can be removed.

8.5 Charging

It is strong belief that it is of great importance to develop and test administrative routines for charging for the ENUM administrative services.

8.6 Other administrative functions in the trial

Not all of the functionality for the permanent solution is possible to implement for the trial. Some of the functionality will have to be simulated. How the following functions are handled should be documented:

- Identification of applicants
- Management of ENUM Domain Names
- Maintenance of NAPTR recourse records
- Cancellation and Porting of E.164 numbers
- Authorization of ENUM entities
- Change of ENUM Registrar

9 For further study

There are several questions that are for further study. It is essential that most of these questions are answered before permanent operation.

9.1 Correspondence between ENUM Domains and E.164 Numbers

Questions concerning how to keep high correlation between ENUM Domain Names and E.164 Number;

- What information from SNPAC can be used for ENUM administration?
- Shall the participation in ENUM of the TSPs be "opt-in"? In that case:
 - Shall only ENUM Domain Names be allowed for E.164 Numbers belonging to TSPs participating in ENUM?
 - How shall porting of E.164 Numbers to TSPs that are not participating be handled?
- How a TSP shall report to the ENUM Tier 1 Registry when ENUM Subscriber is no longer assigned the E.164.
- How a TSP shall report to the ENUM Tier 1 Registry when the ENUM Subscribers corresponding E.164 number is ported to another TSP.
- How the validation function at Tier 1 should be implemented and if it should be directly available for the ENUM Registrars and others.
- How the ENUM Registrar shall identify the applicant.
- The CrefDB is to be defined.

9.2 Automatization

- If the Central Reference Database infrastructure for number portability also can be used for validation and interchange of ENUM-related messages.

9.3 Regulation and supervision

- To find the requirements that have to be put on the ENUM Tier 1 Registry.
- To study if it is possible and advisable to separate the different functions at the ENUM Tier 1 Level into different organisations, e.g. Authorization of ENUM Registrars and TLDs, the technical DNS operation, the administrative service etc.
- How the ENUM Subscriber shall be able to change ENUM registrar.
- How the ENUM market (Application Service Providers, ENUM Tier 2 Name server Providers, ENUM Subscribers and ENUM Registrars) should be supervised?
- How the ENUM Tier 1 Registry should be supervised?
- To identify what legislation/regulation are desirable to apply on the TSPs in the Swedish market.
- If quality requirements and some sort of regulation is needed or if self regulation shall be preferred for ENUM Tier 2 Name server Provider.

9.4 Charging

E.g.:

- Specifying who is charging how, when and what.
 - Whether the TSP should charge the ENUM Tier 1 Registry for the service of validating that the applicant is assigned an E.164 number, or not.
 - Shall the ENUM Tier 1 Registry charge the ENUM Tier 2 Name server Provider for the registration of the DNS server being an integral part of the national ENUM structure.
- Cost models

9.5 PUL

- Must there be an agreed between the customer and the ENUM Registrar that the application for an ENUM entry implies the right for the TSB to notify Tier-1 Registry when the subscription ends.

Appendix A English–Swedish dictionary

Application Service Provider	Tjänsteoperatör
ENUM Registrar	ENUM-ombud
ENUM Subscriber	ENUM-kund
ENUM Tier 1 Registry	ENUM Tier 1 registry
ENUM Tier 2 Name server Provider	?
DNS Service Provider	DNS-operatör
Telephone Service Provider	Teleoperatör

Appendix B Participants in working group ENUM2

The following persons has participated in one or more of the working group ENUM2's meetings.

Anette Hall	NIC-SE
Fredrik Thulin	Stockholms Universitet
Hans Eriksson	Broadsip
Hans-Olof Johansson	Skanova
Joakim Stråmark	PTS
Leif Johansson	Stockholms Universitet
Madlén Frederich	Aerotech Telub AB
Malou Andersson	NIC-SE
Olle Röding	YABSA Informatik AB
Per Dahlberg	Per Dahlberg Elektronik AB
Per-Anders Hurtigh	Domaininfo
Robert Khello	Ericsson
Roland Larsson	Telia Mobile
Staffan Hagnell	II-stiftelsen
Stefan Hagbard	Telia Mobile
Susanne Lindström-Chennell	PTS
Thomas Marténg	Cap Gemeni Ernst & Young
Östen Frånberg	II-stiftelsen

Appendix C Subjects discussed by ENUM WG2

1. Overall description of the “customer process” according to requirements from the ENUM1 WG for the selected test applications.
2. Describe the registration procedures for an ENUM domain.
3. Describe the verification (*authentication*) procedures for an E.164 Subscriber requesting registration of an ENUM domain that is corresponding to the E.164 number.
4. Determine whether the TSP (*access network operator*) should be involved in the verification of the E.164 Subscriber or if the verification (*authentication*) can be made in some other way.
- ~~5. Analyse whether different test applications and customer types require different “customer processes”.~~
6. Determine what type of E.164 numbers in the Swedish numbering plan that can be subject for registration of an ENUM domain name.
7. Determine possible types of organisations for the role of ENUM Registrar
8. Determine possible types of organisations for operation of a Tier 2 DNS, i.e. assume the role of an ENUM Tier 2 Name server provider.
9. Document the different roles a ‘end-user’ can have - ENUM Tier 2 Manager, E.164 Subscriber, holder of one or more ENUM domain names, Registrant when applying for an ENUM domain name and possibly also ENUM Tier 2 Name server Provider if the end-user operates a Tier 2 DNS.
10. Describe the delegation process from the ENUM Tier 1 Registry to a Tier 2 Name server provider.
11. Describe the registration- and customer process in terms of the handling of ‘personal information’ and how consent can be established with the end-user.
12. Describe how E.164-subscribers having a “protected/secret” subscription can be handled if they have requested to use the ENUM based test applications.
13. Determine if a fee from the end-user will be required for a registration of an ENUM Domain Name for the purpose of using a test application.
14. Describe principles for remuneration to be applied between different parties identified by the ENUM1 WG for the proposed architecture during the test period.
15. Analyse the consequences of number portability for E.164-directory numbers as related to ENUM.

Appendix D Grouping of entities

In this appendix some examples are given on how the different entities performing the ENUM administrative services could be grouped. The purpose is not to limit the possibilities, but to give some ideas for what to expect.

D.1 One-stop-shopping

It is expected that many TSP's will offer their customers a full ENUM administrative service and also new ENUM-based applications. This is showed in figure D.1.

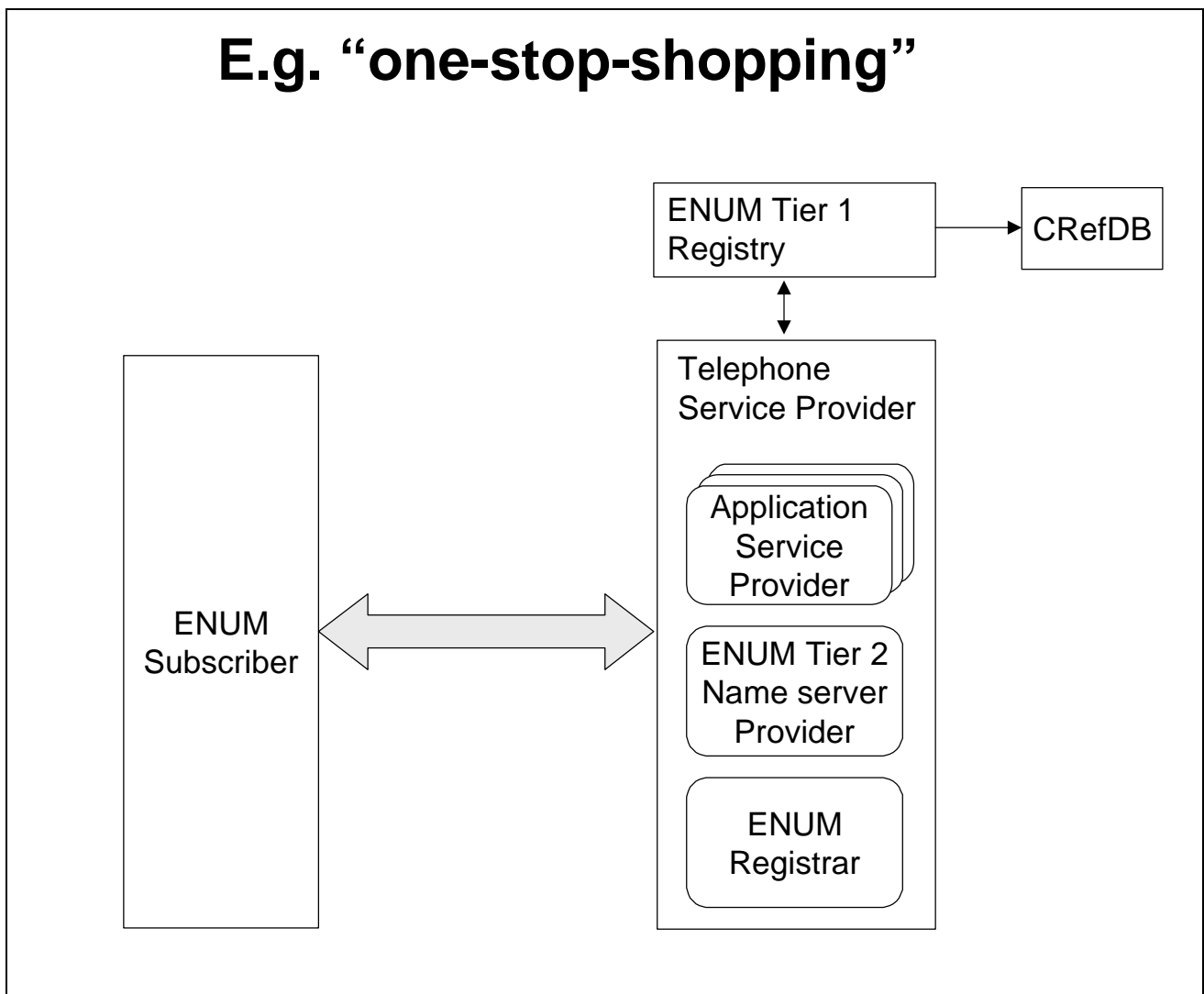

Figure D.1 – One-stop-shopping

D.2 The new ASP's

Hopefully, new businesses will evolve as a consequence of ENUM, where new Application Service providers will be seen. It can be expected that they would like to provide full service except for the telephone service. This is showed in figure D.2.

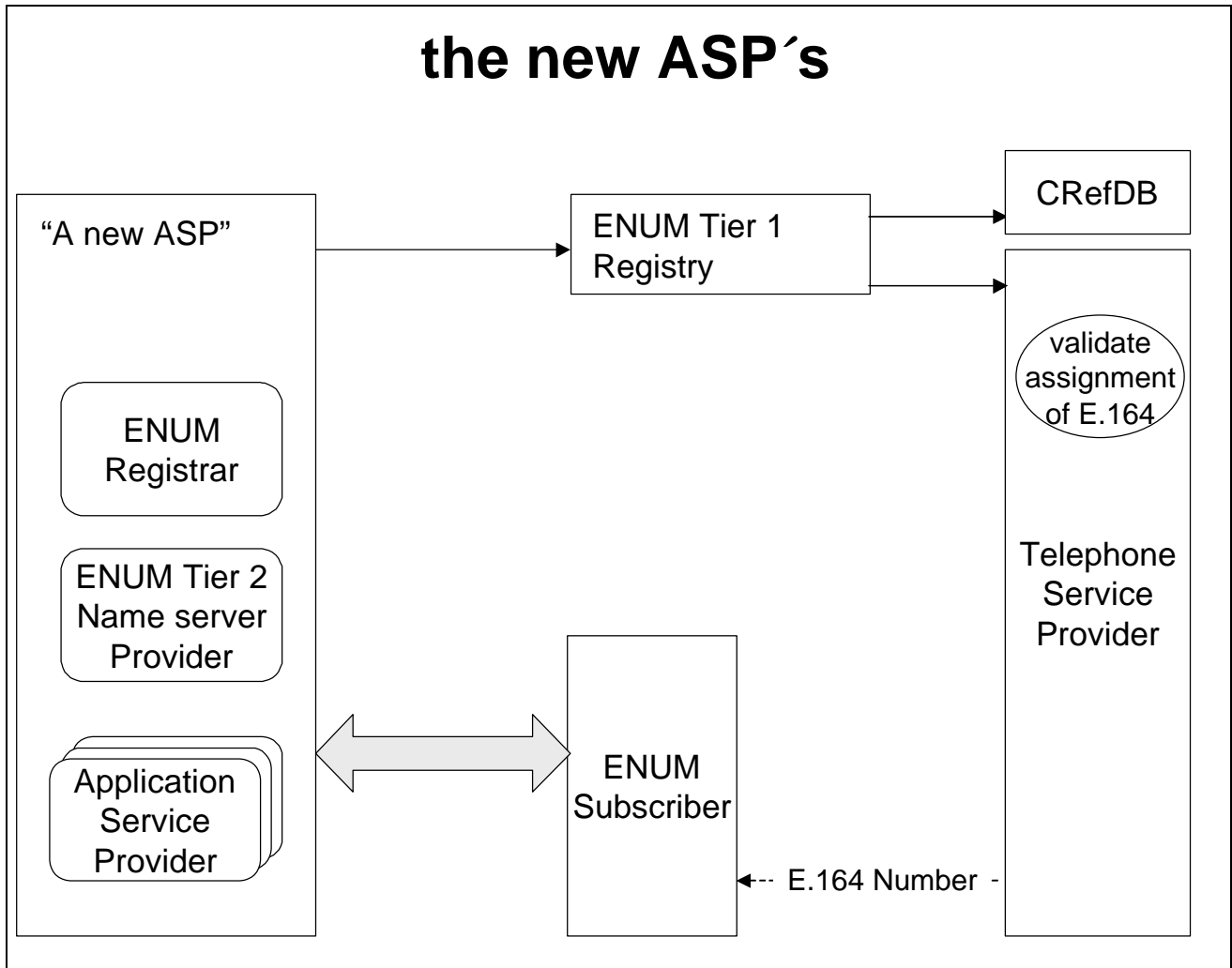

Figure D.1 – The new ASP's